

ROUGH TERRAIN CRANE 100 T CAPACITY



LEVEL UP

POWER IS IN YOUR HANDS

HIGH VERSATILITY

- 100 t lifting capacity
- 47,0 m max boom length with three boom telescoping modes
- 49,5 m max tip height main boom
- Additional 2-section jib of 9/17 m
- 66,0 m max tip height with jib

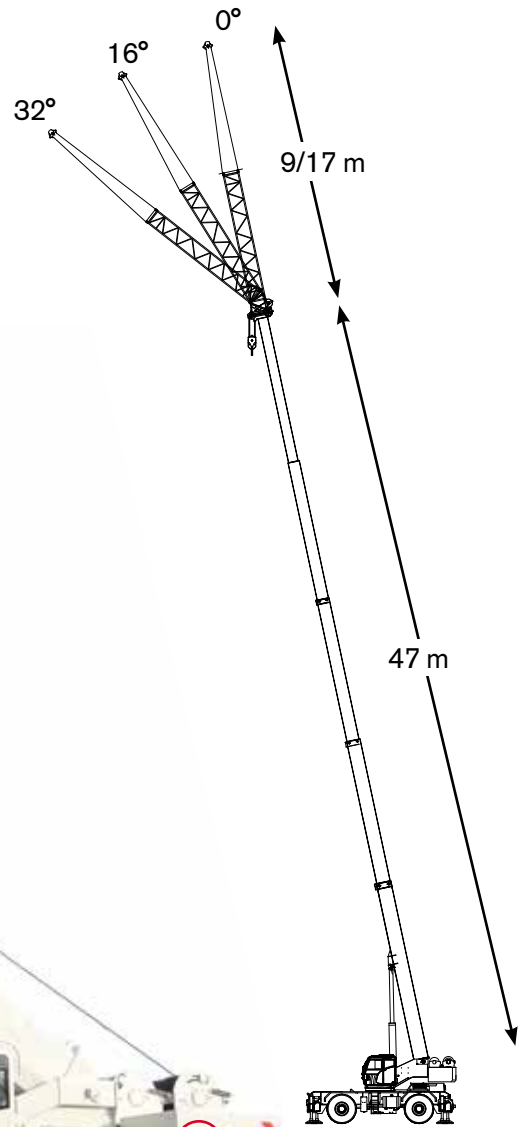

FULL CONTROL.

New TEOS Operating System

- 10" full-color touch screen display with intuitive interface
- Ergonomic electro-proportional joysticks with adjustable responsiveness to operator preferences

TOP CLASS EQUIPMENT

- T-Link Telematics included
- 3 working area LED lights outside the cab included

GREAT COMFORT, EXCELLENT VISIBILITY

- Extra wide and tiltable cabin with large glass surface. No blind spots.
- Integrated heating and air conditioning system

EASY TO HANDLE

- Easy to transport and maneuver
- Only 3 m width
- Four steering modes

WIDE RANGE OF OPTIONS

- Additional 2-section jib of 9/17 m and single sheave
- Auxiliary winch
- Self-removable counterweight
- Up to 4 cameras for enhanced visibility, integrated on main display
- Radio remote control

LEVEL UP

THE STRONGEST STRUCTURE DESIGNED FOR HEAVY LIFTS

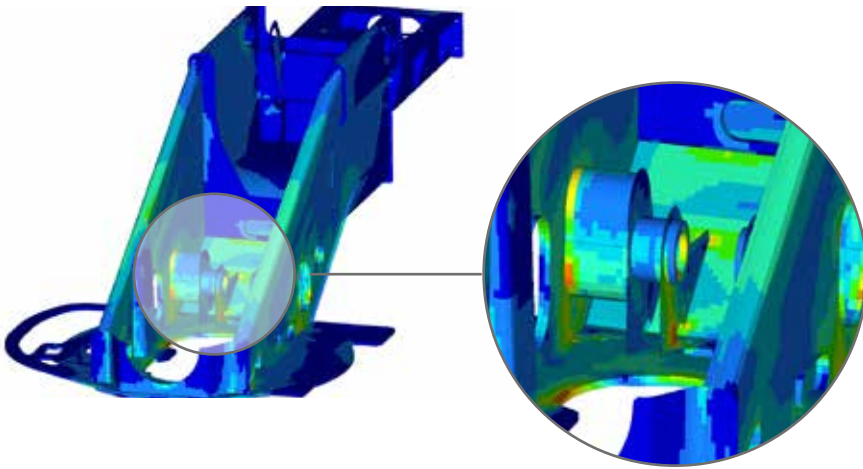

The strongest crane structure

Full crane structural and component FEM* analyses have been developed to deliver the best structural design, capable of delivering reliable performance, even in the most demanding applications.

*FEM: Finite Element Method

3 boom modes

The crane operator has the choice of three boom extension modes to meet different lifting needs.



Mode 1
Stability



Mode 2
Strength



Mode 3
Proportional

4 steering modes

For superior maneuverability around the jobsite, the crane offers 4 different steering modes.



2 wheel-front



2 wheel-rear



4 wheel-concentric



4 wheel-grab

HIGH POWER, LOW FUEL CONSUMPTION WITH IMPROVED ENGINE DESIGN

Cummins QSB6.7 Tier 4 Final/Stage V engine

The Cummins QSB6.7 Tier 4 Final/Stage V 6-cylinder engine delivers high-performance speed and hoisting capabilities. The new **anti-stall control** precisely controls power and speed to offer the lowest fuel consumption.

EcoMode: reduce fuel consumption

EcoMode employs automatic engine throttle to optimize power during crane operation and stand-by to lower fuel consumption.

LEVEL UP

OPTIONAL 9/17 M JIB.

The TRT 100 features an optional 2-section jib with a 9 m lattice main section and 8 m secondary boxed section, providing a total length of 17 m. Jibs are stowed on the crane's side and easily attached to the main boom.

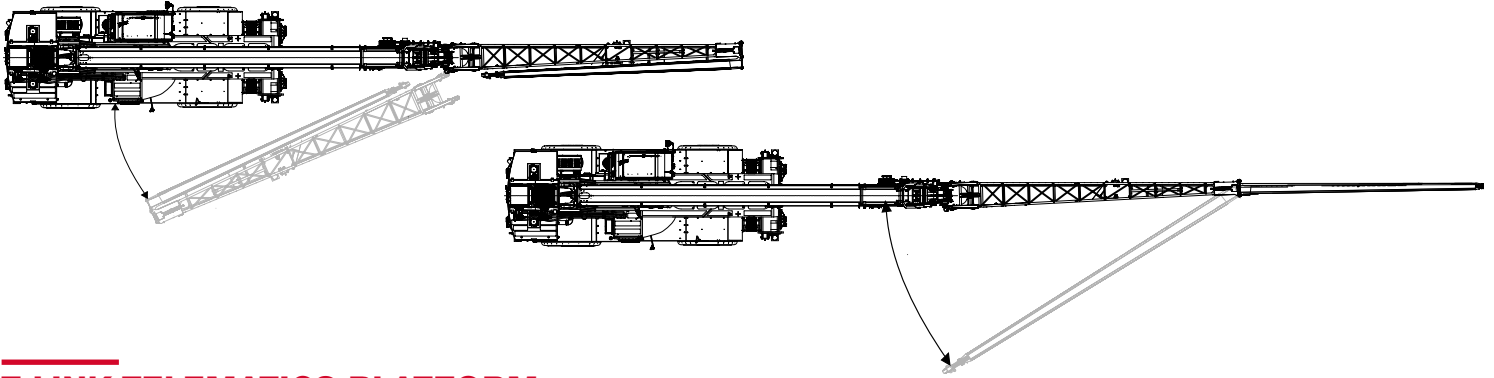

T-LINK TELEMATICS PLATFORM

The T-Link Telematics Platform, included on base unit, allows remote access of crane fleet operating data anytime, anywhere via the internet from your computer, smartphone or tablet.

- ▶ **Cost savings and increased of productivity**
Thanks to T-Link, cost savings and increased productivity can be achieved in all applications.
- ▶ **Better management of maintenance and technical assistance**
Remote monitoring delivers critical vehicle operating data and statistics. Routine maintenance can be scheduled more efficiently and unexpected issues are quickly addressed.
- ▶ **Fleet control**
Using the **Geofence** function, each crane's position is monitored, and the owner is notified in the event the crane leaves its set boundary.
- ▶ **Improved machine management, statistics and real-time data**
A wide range of **real-time operating data** and **fault-codes** are reported to assess fleet performance.
The machine's **Data logger** section collects detailed machine information, such as working hours, load lifting statistics, alarm history, etc.

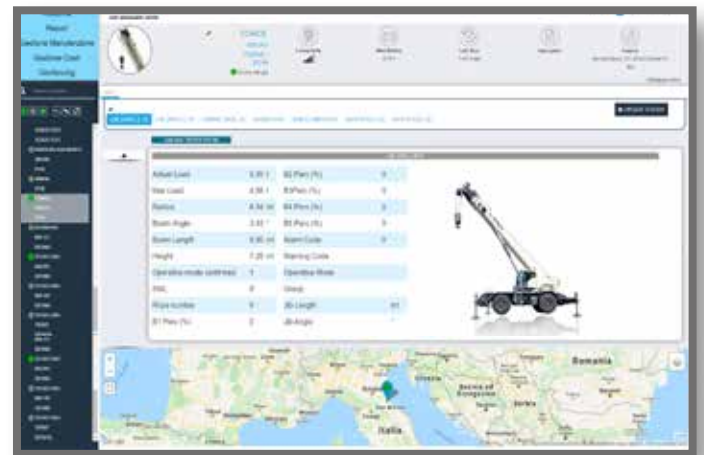

LEVEL UP



TEOS NEW TEOS OPERATING SYSTEM



The new **Terex Operating System TEOS** offers improved information flow and accessibility to increase operating efficiency.

▶ **10" full-color touch screen display**

The new user interface with wide 10" full-color touch screen display features self-explanatory and intuitive icons.

▶ **Intuitive navigation**

Based on extensive customer feedback, information access is quick and easy. The primary and most frequently used functions are immediately accessible, and intuitive controls ensure a short learning curve for new crane operators.

▶ **Diagnostics**

Error messages and warnings are within easy view for enhanced safety. A dedicated menu for diagnostics gives immediate feedback on crane, main component and sensor operating status.

▶ **Options included**

Optional cameras are incorporated in the main display: the operator has full control of the crane from all points of view via a single display. Status of the radio remote control and T-Link platform options can also be seen on the main display.

Customizable electro-proportional joysticks

As desired, the operator can customize the buttons and fine-tune the responsiveness of all crane movements – smoother or prompt reaction – to meet personal preferences. Multiple personal configurations can be saved.

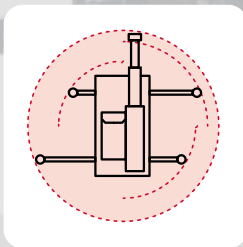

IdeaLift

IdeaLift increases job site versatility by maximizing the load chart with asymmetric outriggers. No matter if fully extended or partially retracted the crane will always give the best option available.

LEVEL UP

TEREX ROUGH TERRAIN CRANES

RT CRANES Italy Srl

Via Cassoletta, 76 - Fraz. Crespellano
40053 Valsamoggia (BO)
Italy

Ph: +39 051 6501011

Email: mktg.cranes@terex.com



www.terex.com/rough-terrain-cranes

Brochure Reference: RT-BR-M-E-TRT 100-02/26



LEVEL UP